

Model

Designation	NLV10CN	Sales code:	105H7004
-------------	----------------	-------------	-----------------

Compressor design

Oil type	Polyolester	Refrigerant(s)	R290
Oil viscosity	32cST	Displacement	10,09cm ³ / 0,62cu.in
Oil quantity	298cm ³ / 10,1fl.oz	Compressors on pallet	80
Refr. charge - tech. limit	150g / 5,3oz		
Free gas volume comp.	2360cm ³ / 79,8fl.oz		
Weight	10,8kg / 23,8lbs		
Motor protection	2# internal		
Winding resist. ph. to ph.	5,3Ω (at 25°C)		
Max. winding temp.	125°C / 257°F		
Max. discharge temp.	130°C / 266°F		



General - Configurations and Applications with NLV10CN and Controller

	Conf. 1	Conf. 2	Conf. 3	Conf. 4
Sales code single pack:	105N4910	105N4960	105N4962	105N4866
Sales code industry pack:	105N4911	105N4961	105N4963	105N4867
Power supply (nominal)	220-240V 50/60Hz	100-240 50/60Hz	100-240 50/60Hz	100-240 50/60Hz
Approvals	VDE,CCC	VDE,UL,CCC,CB	VDE,UL,CCC,CB	CCC,VDE,UL,CB
Refrigerant	R290	R290	R290	R290
Number of phases	1~ AC	1~ AC	1~ AC	1~ AC
Application	LBP+MBP	LBP+MBP	LBP+MBP	LBP+MBP
Starting torque	HST	HST	HST	HST
Hot gas defrost	OK	OK	OK	OK
Long interval pull down	OK	OK	OK	OK
System cooling	fan 3m/s	fan 3m/s	fan 3m/s	fan 3m/s
Note	- / -			

Controller functions

	Conf. 1	Conf. 2	Conf. 3	Conf. 4
Protection	Mechanic	Mechanic	Mechanic	Mechanic
Max output power	1000 W	1000 W	1000 W	1000 W
No of relays	2	2	2	8
Hot gas defrost	yes	yes	yes	yes
AEO speed setting	yes	yes	yes	N
Serial com. (Modbus)	SWI	SWI	SWI	RS485
DWI / Frequency input	yes	yes	yes	N
Note	-	-	US GFCI-Conformity	Under development

Model

Designation

NLV10CN

Sales code:

105H7004

Compressor dimensions

Housing	A Height	203mm / 7,99in
	B Height	197mm / 7,76in
	C Length shell	205mm / 8,07in
	D Length w. cover	254mm / 10in
	E Width	166mm / 6,54in

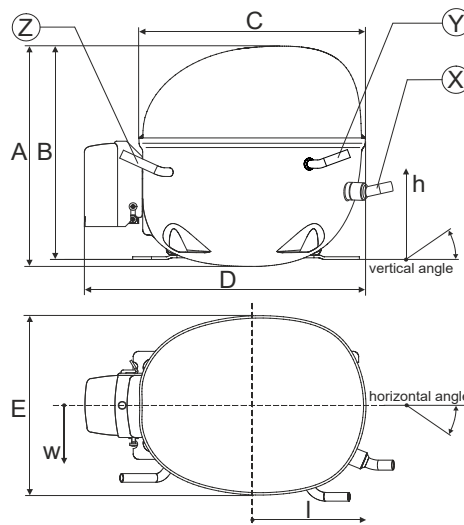

Connectors		Suction	Discharge	Process
		X	Y	Z
Diameter	[mm]	øi 8,11-8,29	øi 6,41-6,59	øi 6,41-6,59
(i:inside, o:outside)	[in]	øi 0,32-0,33	øi 0,25-0,26	øi 0,25-0,26
Material		copper	copper	copper
Horizontal angle	±2°	0°	0°	0°
Vertical angle	±2°	15°	21°	155°
Position l/h/w	[mm]	132/69/56	94/99/86	-111/92/72
	[in]	5,2/2,7/2,2	3,7/3,9/3,4	-4,4/3,6/2,8
Straight tube l.	[mm]	12	12	12
	[in]	0,5	0,5	0,5

Compressor fixation

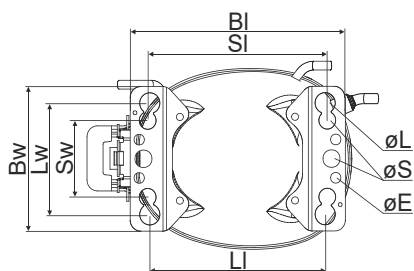

Baseplate	[mm]	[inch]
BI	204	8.03
Bw	132	5.2
øE	ø 9.7	ø 0.38
Large holes	[mm]	[inch]
LI	165	6.5
Lw	101.6	4
øL	ø 19	ø 0.75
Small holes	[mm]	[inch]
SI	170	6.7
Sw	70	2.76
øS	ø 16	ø 0.63

Bolt joint

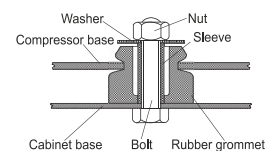

Snap-on

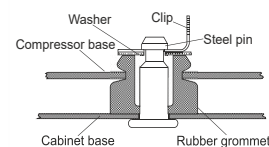

Mounting accessories	one comp.	multi pack
Bolt joint M6 ø16mm	118-1917	118-1918
Bolt joint ø1/4" ø16mm	118-1946	
Bolt joint ø1/4" ø19mm	118-1949	
Snap-on ø7,3 ø16mm	118-1947	118-1919

Application notes

Operation possible until tilted up to 3 degrees

Model

Designation	NLV10CN	220-240V 50/60Hz	Conf. 1	Sales code:	105H7004
Controller	NLV 230V MP				105N4910

Sales code single pack:	105N4910 (1 units)
Sales code industry pack:	105N4911 (8 units)
Adaption to compressor:	detached
Protection class:	IP54
Weight:	1,2 kg / 2,64 lbs
Voltage nom.:	220-240V 50/60Hz
Voltage range:	180-270 V
Max. current:	4,2 A (230 V) / 8,4 A (115 V)
LRA (Locked Rotor Amperage)	1,2 A
Cable length:	680 mm
Compressor speed range:	2000-4500 rpm
Housing plastic:	UL94-5VA

Controller dimensions:

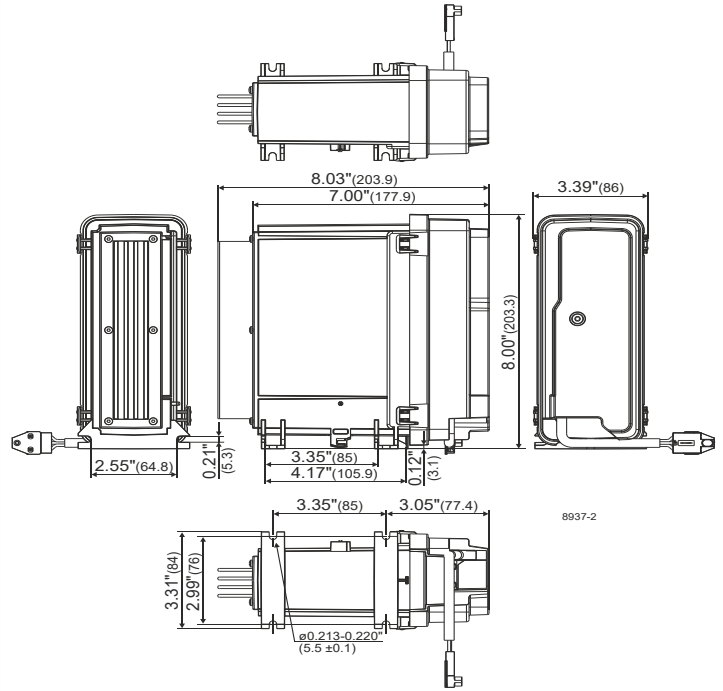

QR Code and Hyperlink leads to the [Operating Instructions](#).

Accessories - check operation manual for details

103N2008	plastic cover	1 pcs
103N9110	plastic cover (MP of 103N2008)	80 pcs

Operation pressure range

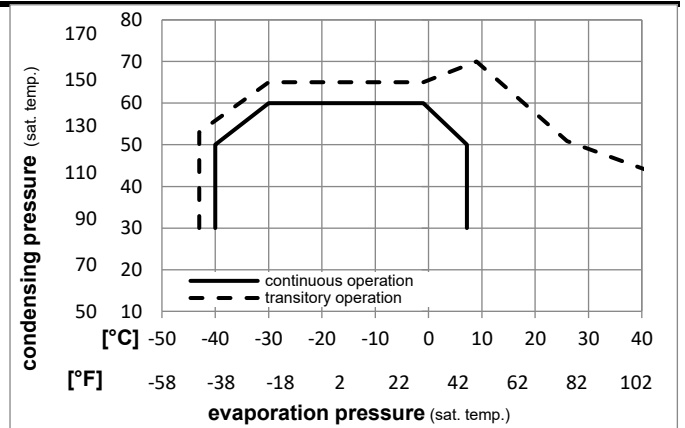

Ambient temperatures / system cooling

Ambient temperature min.:	10°C / 50°F
Ambient temperature max.:	43°C / 110°F

System cooling			
T ambient	LBP	MBP	HBP
32°C / 90°F	fan 3m/s	fan 3m/s	n/a
38°C / 100°F	fan 3m/s	fan 3m/s	n/a
43°C / 110°F	fan 3m/s	fan 3m/s	n/a

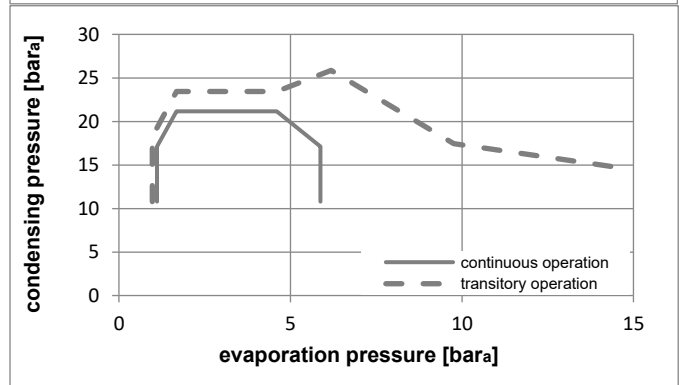

Model

Designation **NLV10CN** **220-240V 50/60Hz** **Conf. 1** Sales code: **105H7004**

Controller **NLV 230V MP** **105N4910**

Controller connections

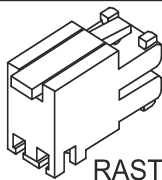
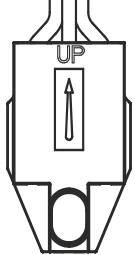
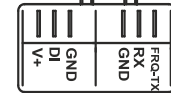
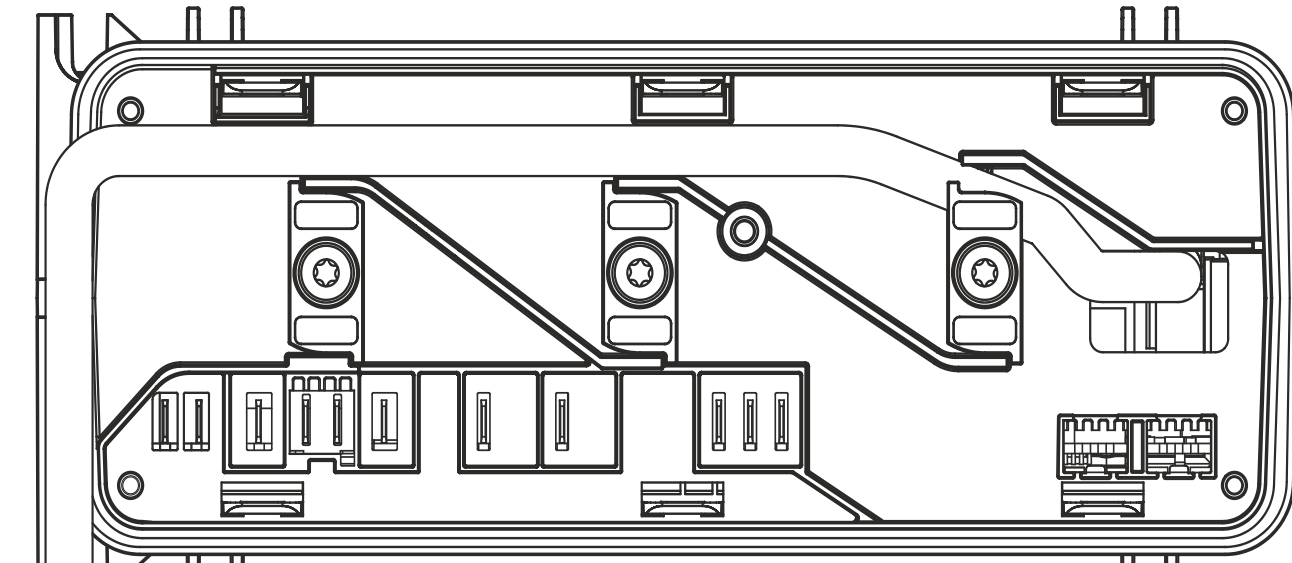

RAST 5

Spade connectors 6.3 x 0.8

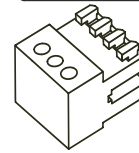

RAST 2.5

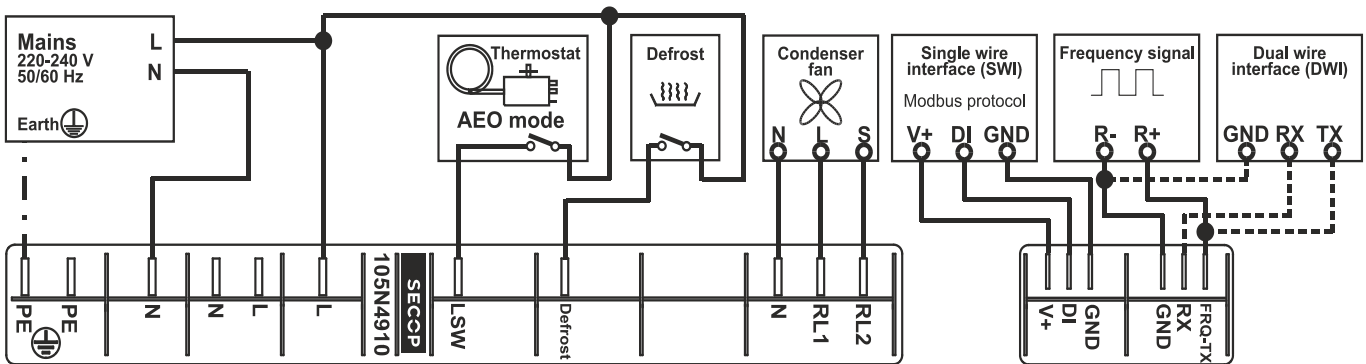

Model

Designation	NLV10CN	100-240 50/60Hz	Conf. 2	Sales code:	105H7004
Controller	NLV MV MP				105N4960

Sales code single:	105N4960 (1 units)
Sales code industry pack:	105N4961 (8 units)
Adaption to compressor:	detached
Protection class:	IP54
Weight:	1,2 kg / 2,64 lbs
Voltage nom.	100-240 50/60Hz
Voltage range	90-150/180-270 V
Max. current:	4,2 A (230 V) / 8,4 A (115 V)
LRA (Locked Rotor Amperage)	1,2 A
Cable length:	680 mm
Compressor speed range:	2000-4500 rpm
Housing plastic:	UL94-5VA

Controller dimensions:

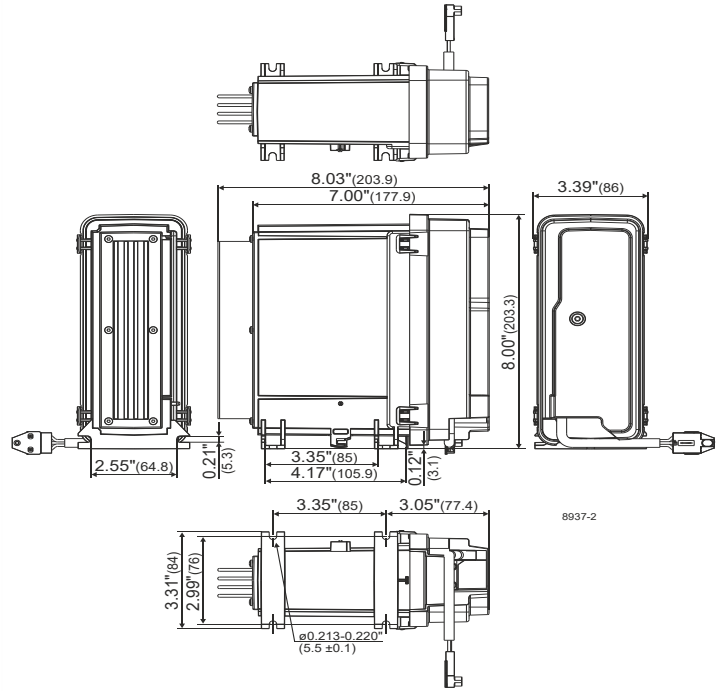

QR Code and Hyperlink leads to the [Operating Instructions.](#)

Accessories - check operation manual for details

103N2008	plastic cover	1 pcs
103N9110	plastic cover (MP of 103N2008)	80 pcs

Ambient temperatures / system cooling

Ambient temperature min.:	10°C / 50°F
Ambient temperature max.:	43°C / 110°F

System cooling			
T ambient	LBP	MBP	HBP
32°C / 90°F	fan 3m/s	fan 3m/s	n/a
38°C / 100°F	fan 3m/s	fan 3m/s	n/a
43°C / 110°F	fan 3m/s	fan 3m/s	n/a

Operation pressure range

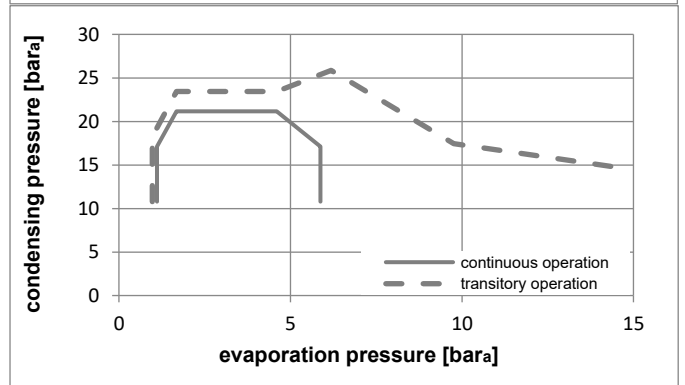
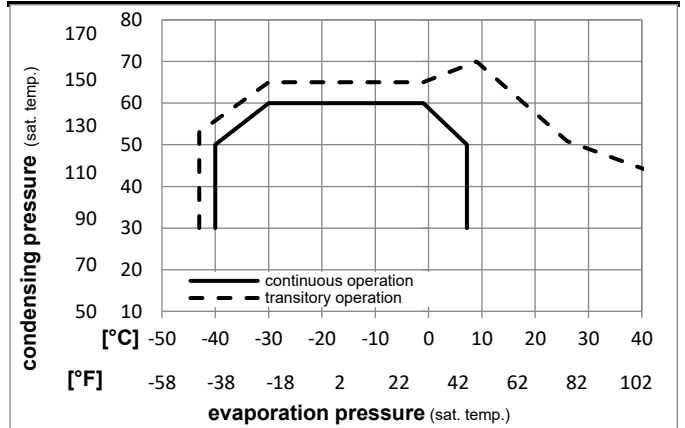

Model

Designation	NLV10CN	100-240 50/60Hz	Conf. 2	Sales code:	105H7004
-------------	---------	-----------------	---------	-------------	----------

Controller	NLV MV MP				105N4960
------------	-----------	--	--	--	----------

Controller connections

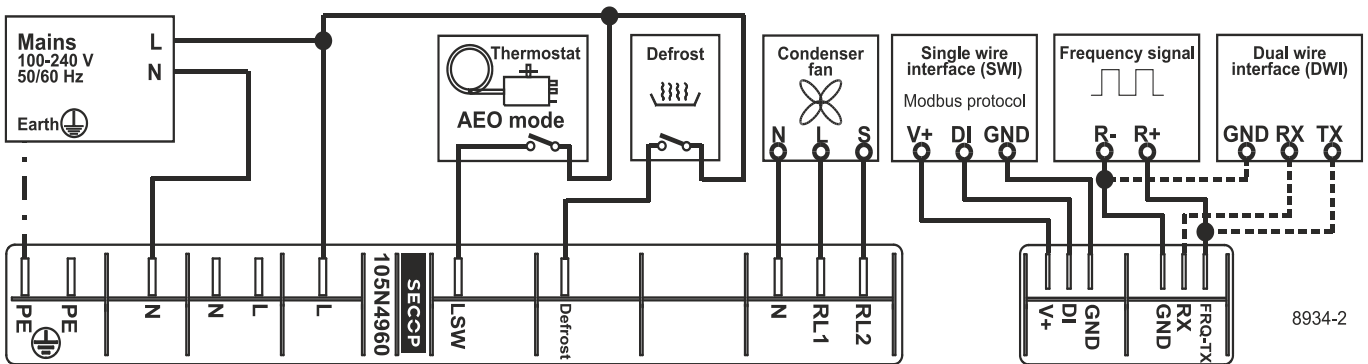
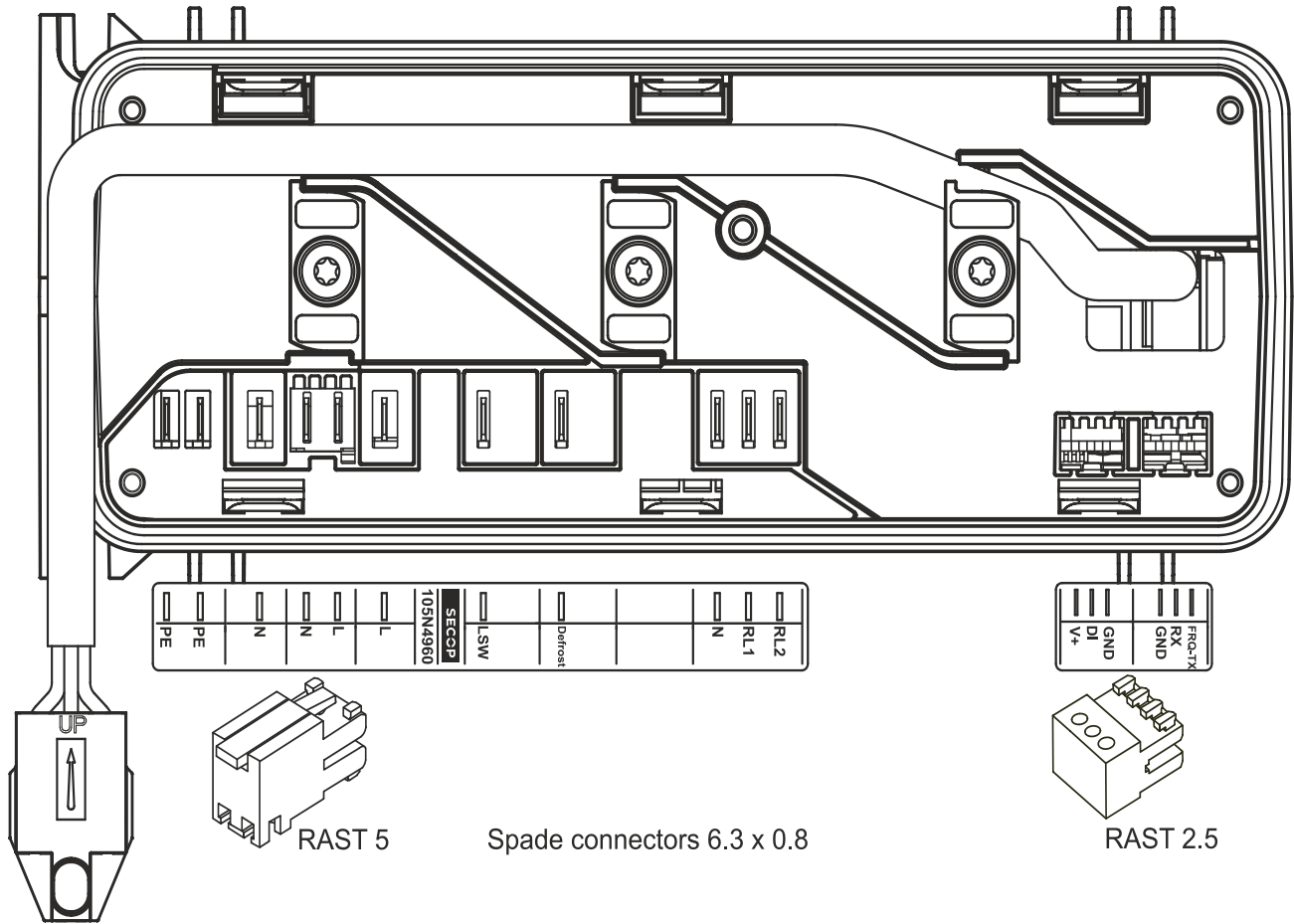

Model

Designation **NLV10CN** **100-240 50/60Hz** **Conf. 2** Sales code: **105H7004**

Controller **NLV MV MP** **105N4960**

Optimization + standard conditions

220V, 50Hz, Rpm_N 4500, fan 3m/s

	Evaporating pressure (saturation temperature)				Condensing pressure (saturation temperature)			COP	EER	Power consumption			ASHRAE LBP			
	pe	pc	RGT	Tliq	Return gas temp.	Liquid temp.	Cooling capacity			P1	I	Ref. mass flow				
	[°C]	[°C]	[°C]	[°C]	[°C]	[°C]	[W]	[Btu/h]	[kcal/h]	[W/W]	[Btu/Wh]	[kcal/Wh]	[W]	[A]	[kg/h]	
	-23	54	32	32			747,9	2554	643,7	1,76	6,01	1,52	424,8	2,21	7,57	ASHRAE LBP
	[°F]															
	-10	130	90	90												
	[°C]	-25	55	32	55		560,5	1914	482,4	1,37	4,69	1,18	407,9	2,11	6,98	CECOMAF LBP
	[°F]															
	-13	131	90	131												
	[°C]	-35	40	20	40		412,3	1408	354,9	1,38	4,71	1,19	299,1	1,44	4,71	EN12900 LBP
	[°F]															
	-31	104	68	104												
	[°C]	-7	54	35	46		1359,1	4641	1169,6	2,22	7,58	1,91	612,6	3,25	15,50	ASHRAE MBP
	[°F]															
	20	130	95	115												
	[°C]	-10	55	32	55		1077,4	3680	927,2	1,87	6,38	1,61	576,8	3,06	13,63	CECOMAF MBP
	[°F]															
	14	131	90	131												
	[°C]	-10	45	20	45		1187,8	4057	1022,3	2,20	7,50	1,89	540,8	2,78	14,58	EN12900 MBP
	[°F]															
	14	113	68	113												

Standard conditions with different RPM

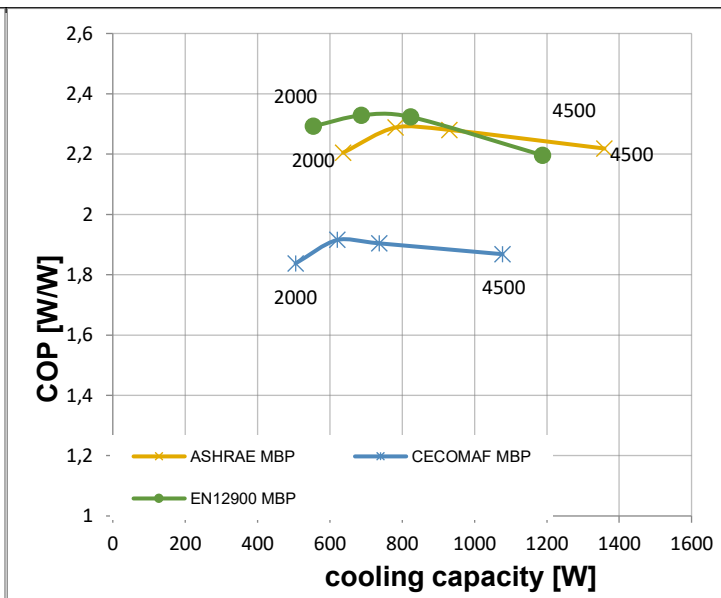
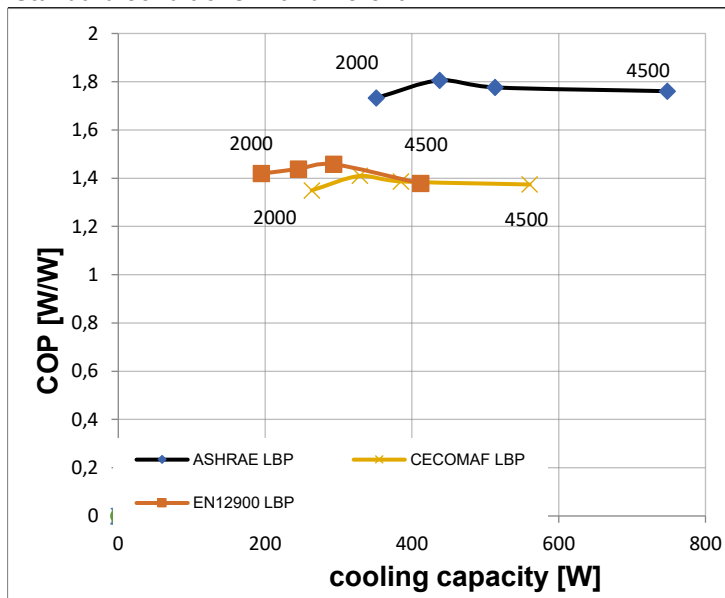

Test conditions:

	pe [°C]	pc [°C]	Tliq [°C]	Tsuc [°C]		pe [°C]	pc [°C]	Tliq [°C]	Tsuc [°C]
ASHRAE LBP	-23,33	54,44	32,22	32,22	ASHRAE MBP	-6,66	54,44	46,11	35
CECOMAF LBP	-25	55	55	32	CECOMAF MBP	-10	55	55	32
EN12900 LBP	-35	40	40	20	EN12900 MBP	-10	45	45	20

Model

Designation	NLV10CN	100-240 50/60Hz	Conf. 3	Sales code:	105H7004
Controller	NLV MV MP US				105N4962

Sales code single:	105N4962 (1 units)
Sales code industry pack:	105N4963 (8 units)
Adaption to compressor:	detached
Protection class:	IP54
Weight:	1,2 kg / 2,64 lbs
Voltage nom.	100-240 50/60Hz
Voltage range	90-150/180-270 V
Max. current:	4,2 A (230 V) / 8,4 A (115 V)
LRA (Locked Rotor Amperage)	1,2 A
Cable length:	915 mm
Compressor speed range:	2000-4500 rpm
Housing plastic:	UL94-5VA

Controller dimensions:

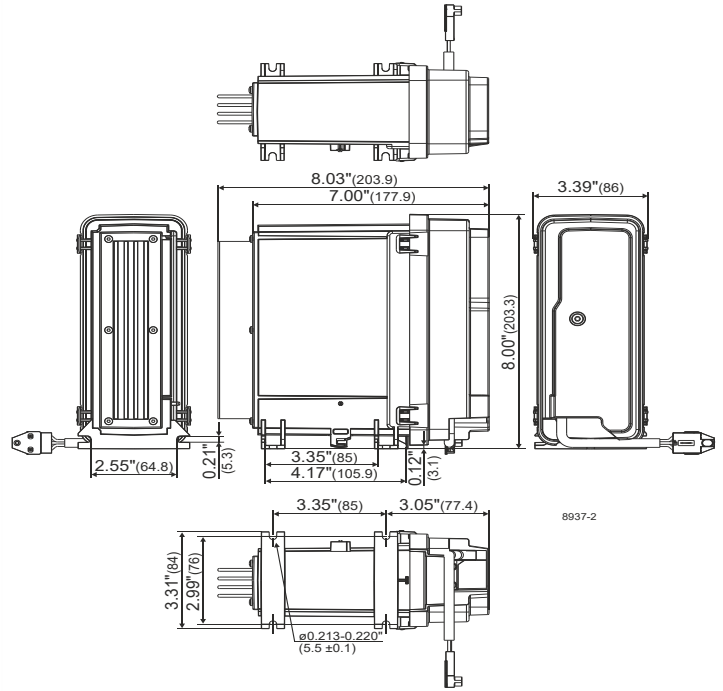

QR Code and Hyperlink leads to the [Operating Instructions.](#)

Accessories - check operation manual for details

103N2008	plastic cover	1 pcs
103N9110	plastic cover (MP of 103N2008)	80 pcs
103N1004	cord relief	1 pcs

Ambient temperatures / system cooling

Ambient temperature min.:	10°C / 50°F
Ambient temperature max.:	43°C / 110°F

System cooling			
T ambient	LBP	MBP	HBP
32°C / 90°F	n/a	fan 3m/s	n/a
38°C / 100°F	fan 3m/s	fan 3m/s	n/a
43°C / 110°F	fan 3m/s	fan 3m/s	n/a

Operation pressure range

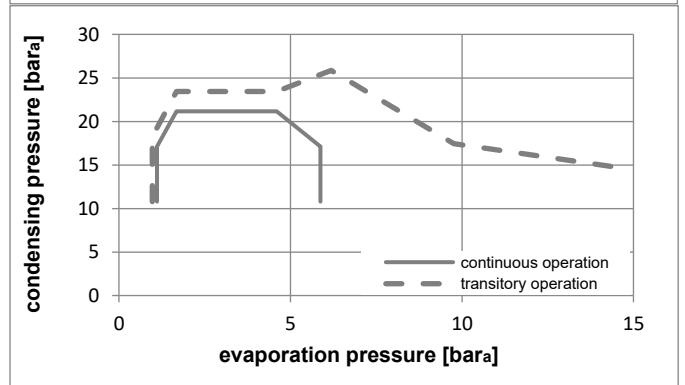
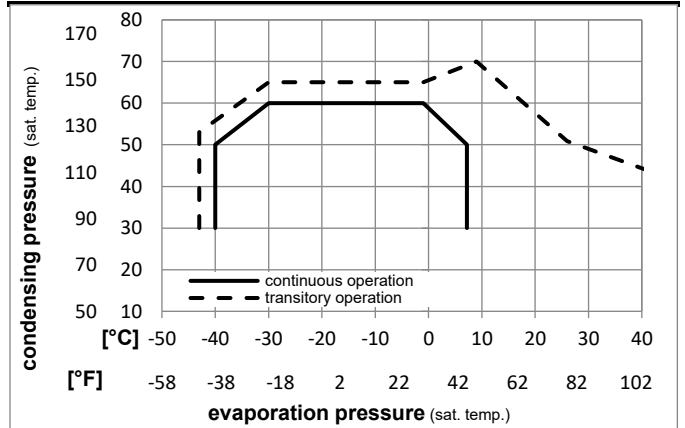

Model

Designation **NLV10CN** **100-240 50/60Hz** **Conf. 3** Sales code: **105H7004**

Controller **NLV MV MP US** **105N4962**

Controller connections

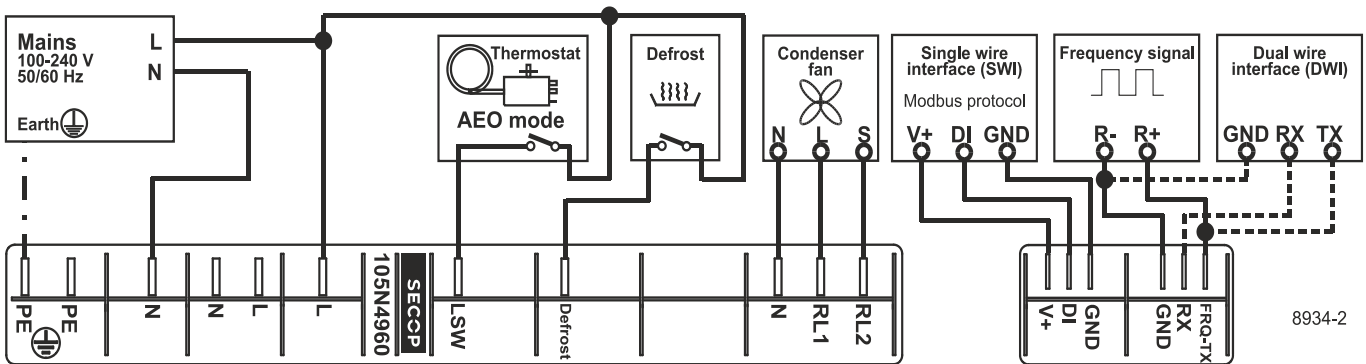
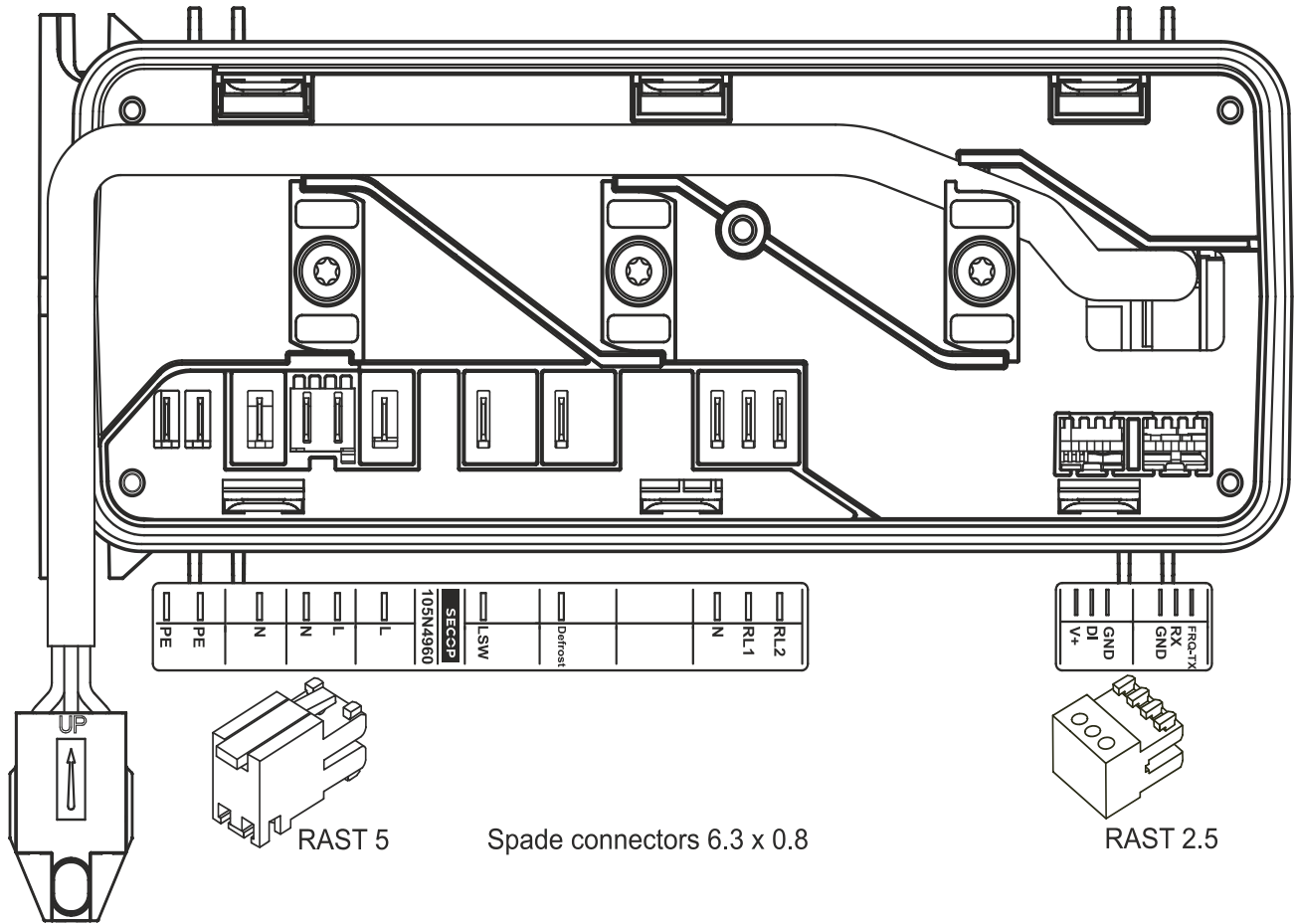

Model

Designation **NLV10CN** **100-240 50/60Hz** **Conf. 3** Sales code: **105H7004**

Controller **NLV MV MP US** **105N4962**

Optimization + standard conditions

220V, 50Hz, Rpm_N 4500, fan 3m/s

	Evaporating pressure (saturation temperature)				Condensing pressure (saturation temperature)			Cooling capacity	COP	EER	Power consumption			
	pe	pc	Return gas temp.		RGT	Tliq	P1				Current consumption		m	
			[°C]	[°F]							[W]	[A]		
	[°C]	[°F]	[W]	[Btu/h]	[kcal/h]	[W/W]	[Btu/Wh]	[kcal/Wh]	[W]	[A]	[kg/h]			
	-23	54	32	32	747,9	2554	643,7	1,76	6,01	1,52	424,8	2,21	7,57	ASHRAE LBP
	-10	130	90	90										
	-25	55	32	55	560,5	1914	482,4	1,37	4,69	1,18	407,9	2,11	6,98	CECOMAF LBP
	-13	131	90	131										
	-35	40	20	40	412,3	1408	354,9	1,38	4,71	1,19	299,1	1,44	4,71	EN12900 LBP
	-31	104	68	104										
	-7	54	35	46	1359,1	4641	1169,6	2,22	7,58	1,91	612,6	3,25	15,50	ASHRAE MBP
	20	130	95	115										
	-10	55	32	55	1077,4	3680	927,2	1,87	6,38	1,61	576,8	3,06	13,63	CECOMAF MBP
	14	131	90	131										
	-10	45	20	45	1187,8	4057	1022,3	2,20	7,50	1,89	540,8	2,78	14,58	EN12900 MBP
	14	113	68	113										

Standard conditions with different RPM

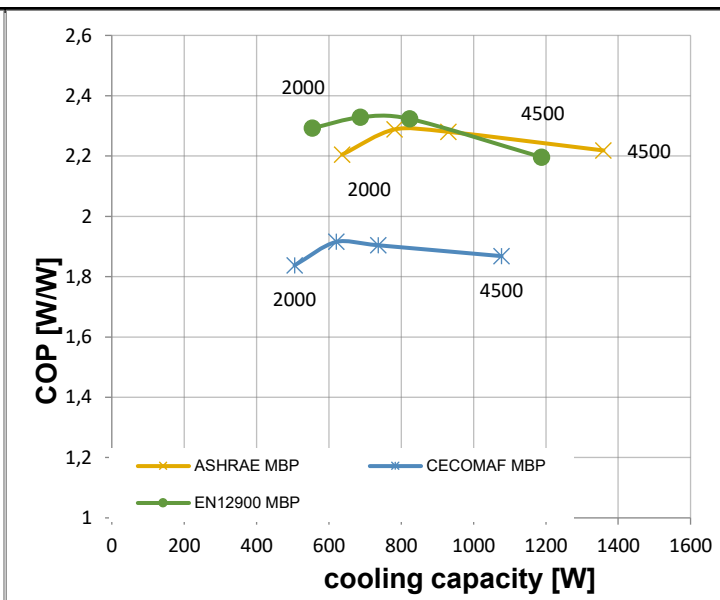
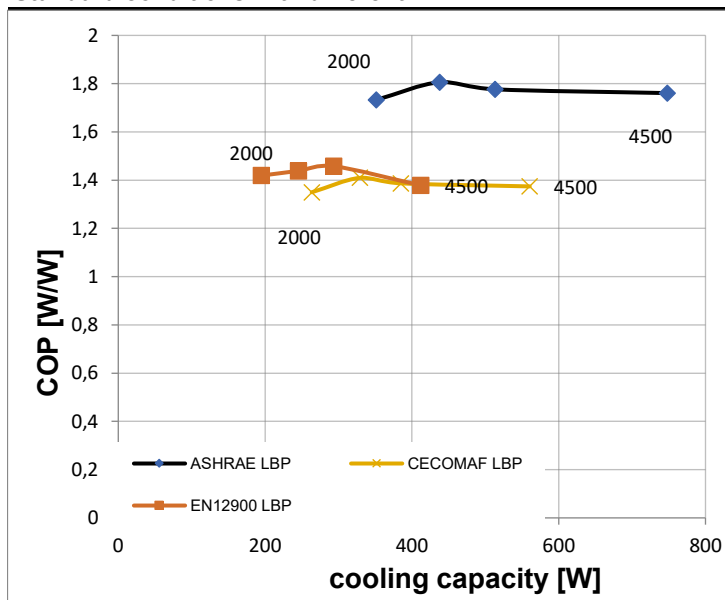

Test conditions:	pe [°C]	pc [°C]	Tliq [°C]	Tsuc [°C]	pe [°C]	pc [°C]	Tliq [°C]	Tsuc [°C]	
ASHRAE LBP	-23,33	54,44	32,22	32,22	ASHRAE MBP	-6,66	54,44	46,11	35
CECOMAF LBP	-25	55	55	32	CECOMAF MBP	-10	55	55	32
EN12900 LBP	-35	40	40	20	EN12900 MBP	-10	45	45	20

Model

Designation	NLV10CN	100-240 50/60Hz1~ AC	Conf. 4	Sales code:	105H7004
Controller	NLV MV XT				105N4866

Sales code single:	105N4866 (1 units)
Sales code industry pack:	105N4867 (8 units)
Adaption to compressor:	detached
Protection class:	IP43
Weight:	1,2 kg / 2,64 lbs
Voltage nom.	100-240 50/60Hz1~ AC
Voltage range	90-150/180-270 V
Max. current:	4,2 A (230 V) / 8,4 A (115 V)
LRA (Locked Rotor Amperage)	1,2 A
Cable length:	680 mm
Compressor speed range:	2000-4500 rpm
Housing plastic:	UL94-5VA

Controller dimensions:

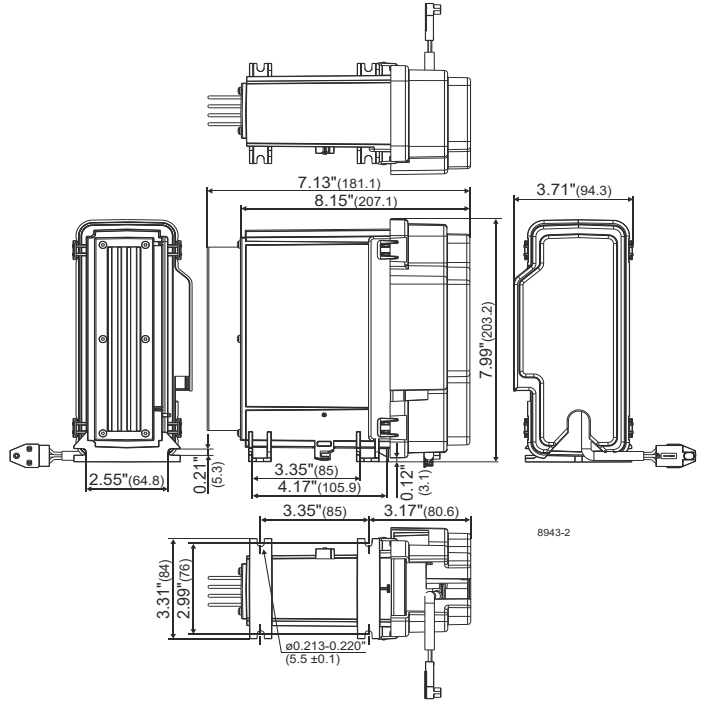

QR Code and Hyperlink leads to the [Operating Instructions](#).

Accessories - check operation manual for details

103N2008	plastic cover	1 pcs
103N9110	plastic cover (MP of 103N2008)	80 pcs

Ambient temperatures / system cooling

Ambient temperature min.:	10°C / 50°F
Ambient temperature max.:	43°C / 110°F

System cooling			
T ambient	LBP	MBP	HBP
32°C / 90°F	fan 3m/s	fan 3m/s	n/a
38°C / 100°F	fan 3m/s	fan 3m/s	n/a
43°C / 110°F	fan 3m/s	fan 3m/s	n/a

Operation pressure range

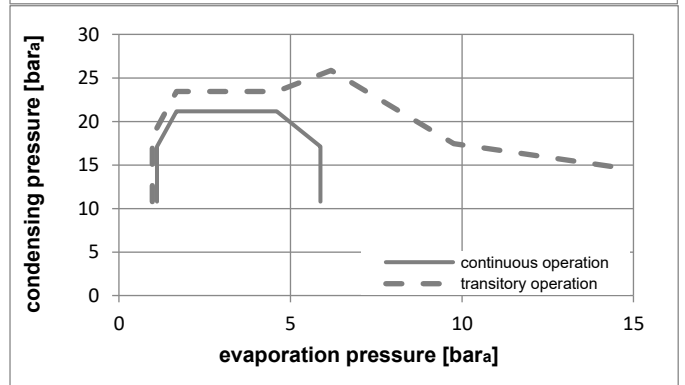
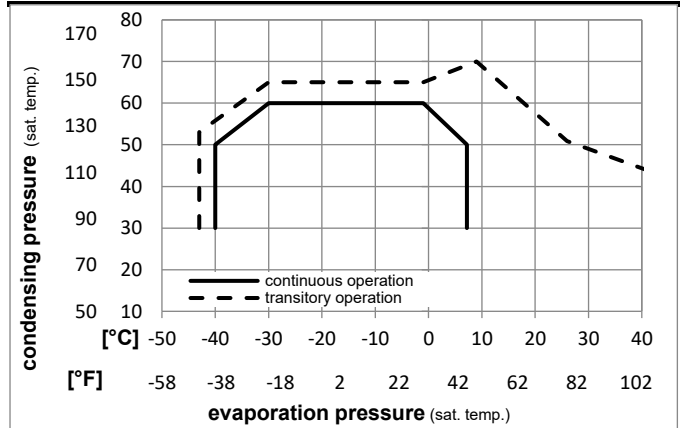

Model

Designation **NLV10CN** **100-240 50/60Hz1~ AC** **Conf. 4** Sales code: **105H7004**

Controller **NLV MV XT** **105N4866**

Controller connections

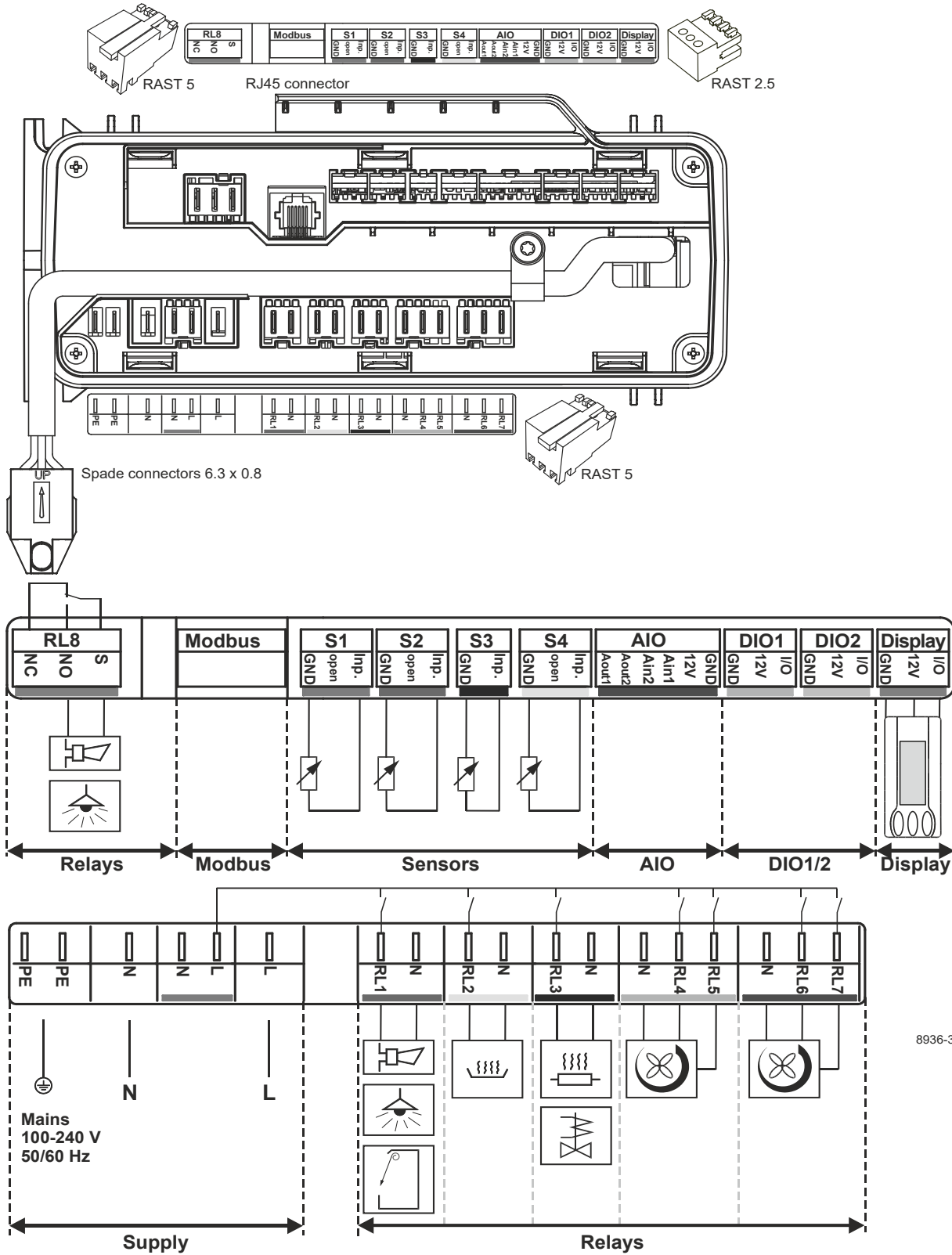

Model

Designation **NLV10CN** **100-240 50/60Hz1~ AC** **Conf. 4** Sales code: **105H7004**

Controller **NLV MV XT** **105N4866**

Optimization + standard conditions

220V, 50Hz, Rpm_N 4500, fan 3m/s

	Evaporating pressure (saturation temperature)				Condensing pressure (saturation temperature)			Return gas temp.			Liquid temp.			Cooling capacity			COP	EER	Power consumption			ASHRAE LBP
	pe	pc	RGT	Tliq	[W]	[Btu/h]	[kcal/h]	[W/W]	[Btu/Wh]	[kcal/Wh]	P1	I	ṁ	[W]	[A]	[kg/h]						
[°C]	-23	54	32	32	747,9	2554	643,7	1,76	6,01	1,52	424,8	2,21	7,57									
[°F]	-10	130	90	90																		
[°C]	-25	55	32	55	560,5	1914	482,4	1,37	4,69	1,18	407,9	2,11	6,98									
[°F]	-13	131	90	131																		
[°C]	-35	40	20	40	412,3	1408	354,9	1,38	4,71	1,19	299,1	1,44	4,71									
[°F]	-31	104	68	104																		
[°C]	-7	54	35	46	1359,1	4641	1169,6	2,22	7,58	1,91	612,6	3,25	15,50									
[°F]	20	130	95	115																		
[°C]	-10	55	32	55	1077,4	3680	927,2	1,87	6,38	1,61	576,8	3,06	13,63									
[°F]	14	131	90	131																		
[°C]	-10	45	20	45	1187,8	4057	1022,3	2,20	7,50	1,89	540,8	2,78	14,58									
[°F]	14	113	68	113																		

Standard conditions with different RPM

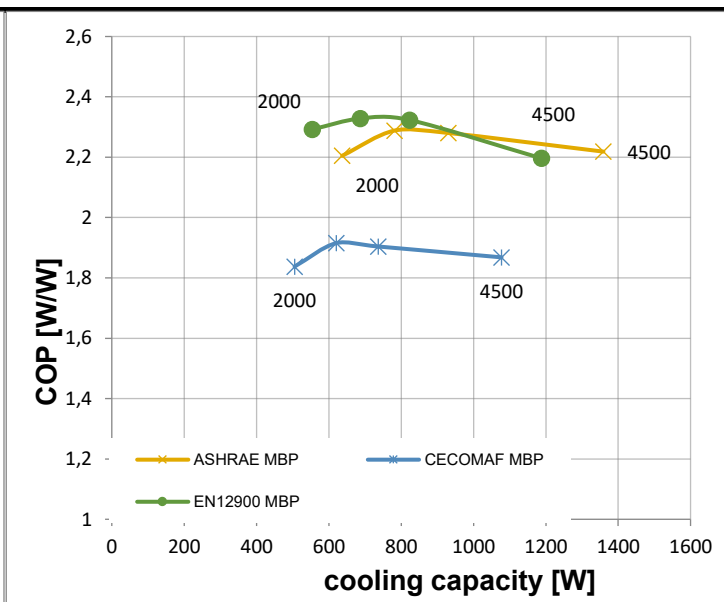
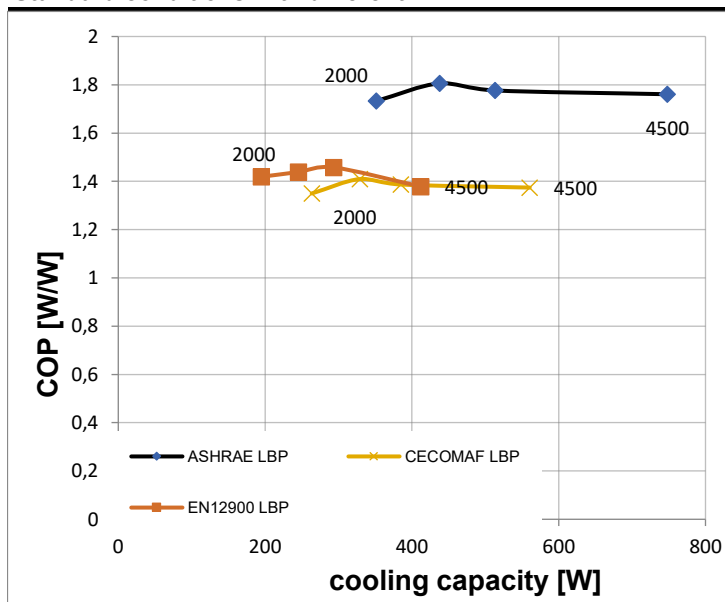

Test conditions:	pe [°C]	pc [°C]	Tliq [°C]	Tsuc [°C]	pe [°C]	pc [°C]	Tliq [°C]	Tsuc [°C]	
ASHRAE LBP	-23,33	54,44	32,22	32,22	ASHRAE MBP	-6,66	54,44	46,11	35
CECOMAF LBP	-25	55	55	32	CECOMAF MBP	-10	55	55	32
EN12900 LBP	-35	40	40	20	EN12900 MBP	-10	45	45	20